

Table of Contents

Table of Contents	1
Part p1.....	2
Part p2.....	4
Part p3a	6
Part p3b.....	10
Part p4.....	11

Part p1

Qty: 2 X

Part p1 is a circular disc of $\frac{1}{8}$ inch thickness, with a side wall $1 \frac{1}{2}$ inches high, running along one fourth of its circumference.

This side wall has a $\frac{3}{4}$ inch diameter circular hole in its center.

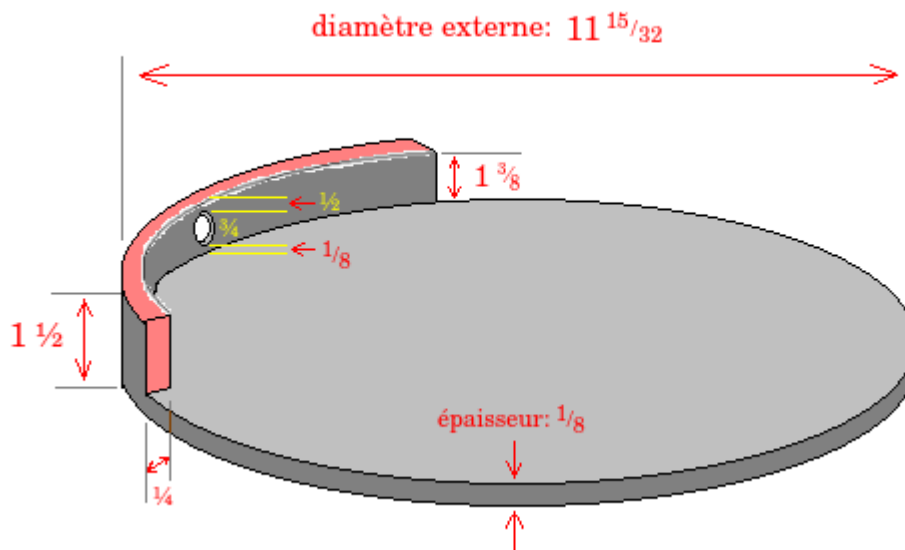

figure 1.a - part p1, $\frac{3}{4}$ view

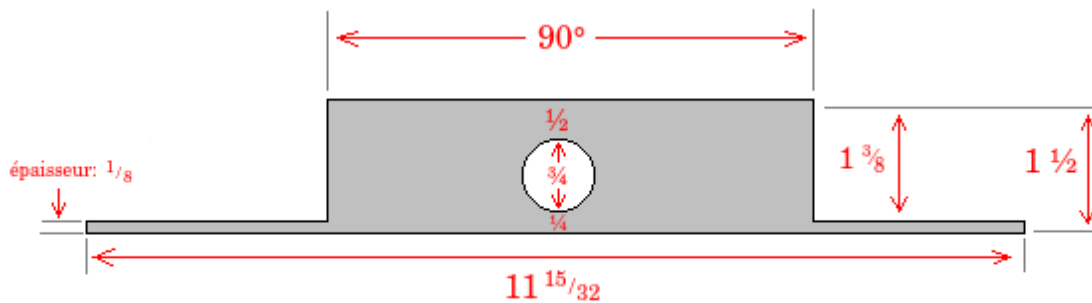

figure 1.b - part p1, profile view

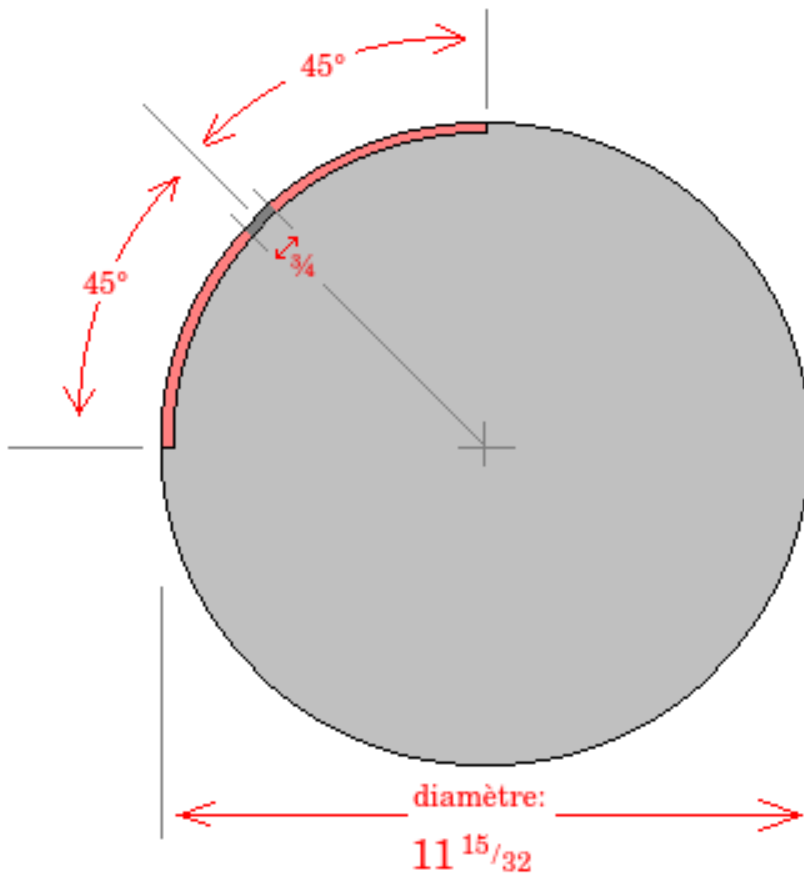

figure 1.c - part p1, top view

The $\frac{1}{4}$ inch slit on the right follows a curve defined by the following cartesian equations :

$$x(\theta) = 7\frac{1}{8} - \left(5\frac{1}{8}\right) * \cos \theta$$

$$y(\theta) = \sin \theta * \left(\left(\frac{7\frac{1}{8}}{\cos \theta} \right) - 5\frac{1}{8} \right)$$

for θ values between -45° and $+45^\circ$
in relation to the center of the disc

If your systems accept polar coordinates, the same curve may be described using this unique equation :

$$r(\theta) = \left(\frac{7\frac{1}{8}}{\cos \theta} \right) - 5\frac{1}{8}$$

The start and end points of this curve ($\theta=-45^\circ$ and $\theta=+45^\circ$) each mark the center of a $\frac{1}{4}$ inch diameter hole, forming one extremity of the slit :

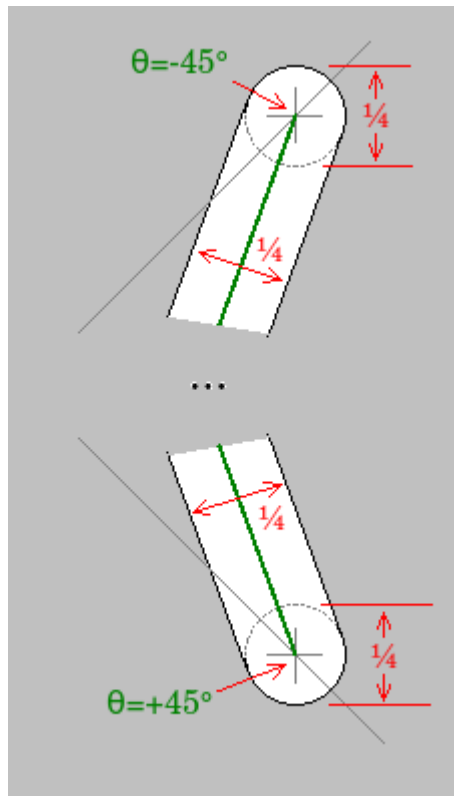

figure 2.b - close-up view on the extremities of the right-side slit

Part p3a

Qty: 1 X

This part is based on a cylindrical form that has a 12 inch outside diameter, 3 ¼ inches high, with the sides being ¼ inch thick. Two slits are present along the side :

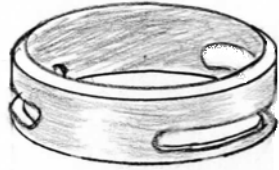

figure 3.a - part p3a, ¾ view

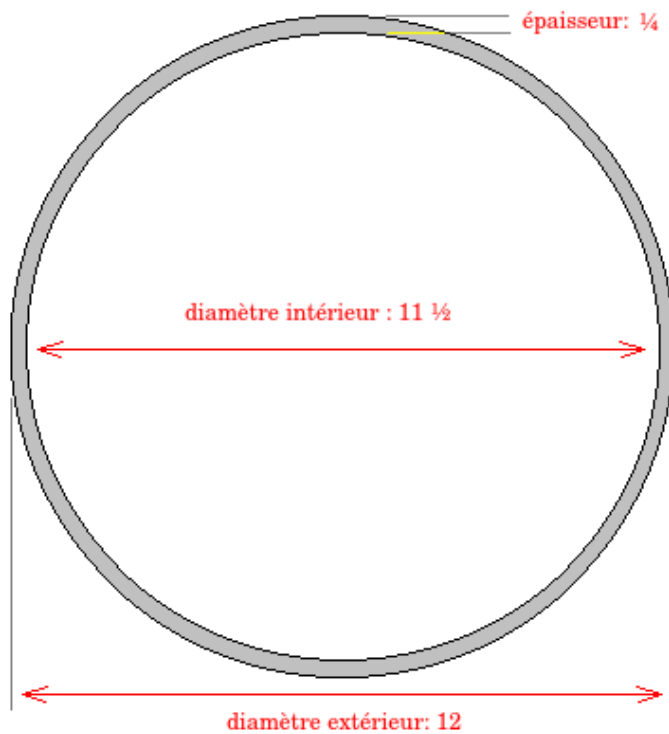

figure 3.b - part p3a, top view

Please note :

- a) the top part is beveled at 45°
(as can be seen below in figure 3.c)
- b) Two slits need to be cutout along the sides
(see figures 3.d to 3.g)

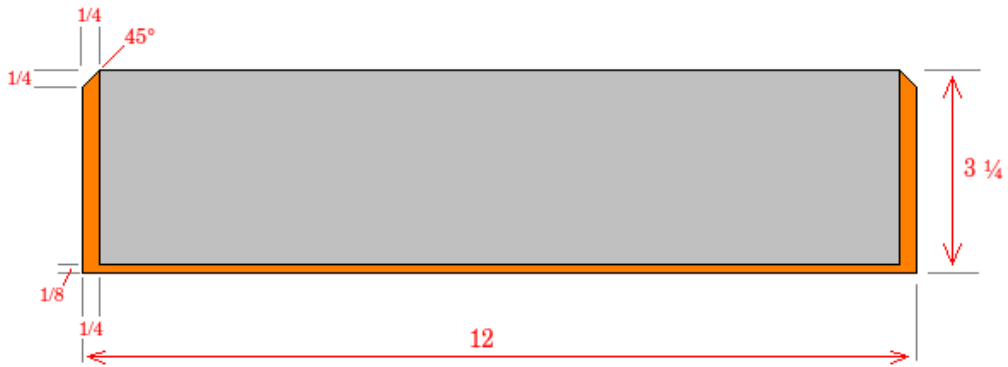

figure 3.c - part p3a, section view

As mentioned above, 2 slits need to be positioned along the side of this piece. It is important that the relative positioning of the slits be respected.

Here are the specs for the first slit (*fente 1*) :

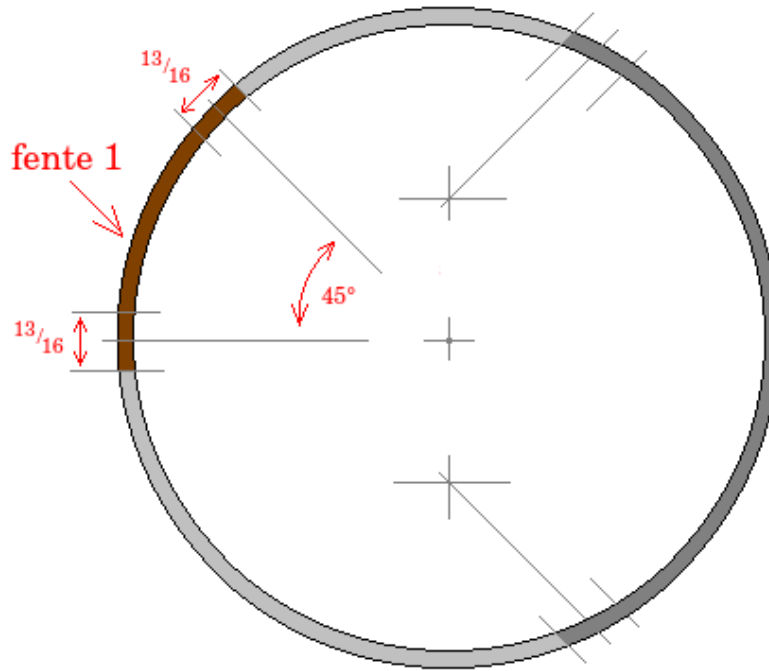

figure 3.d - part p3a, slit 1 (fente 1) : top view

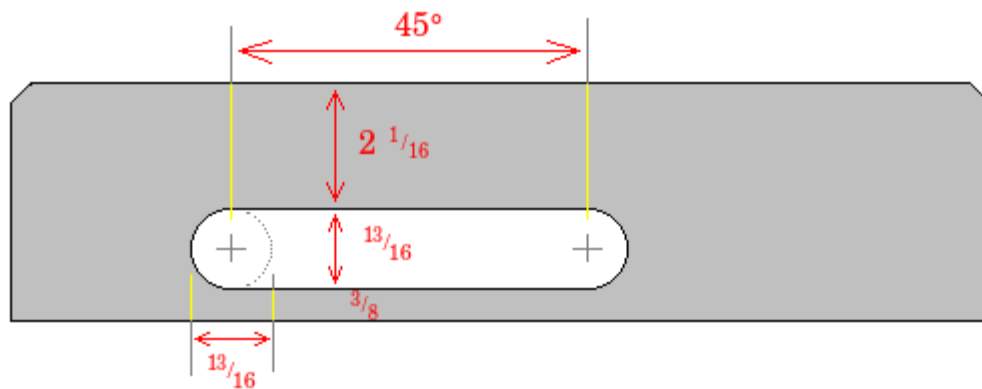

figure 3.e - part p3a, slit 1, side view

As for the second slit (*fente 2*) :

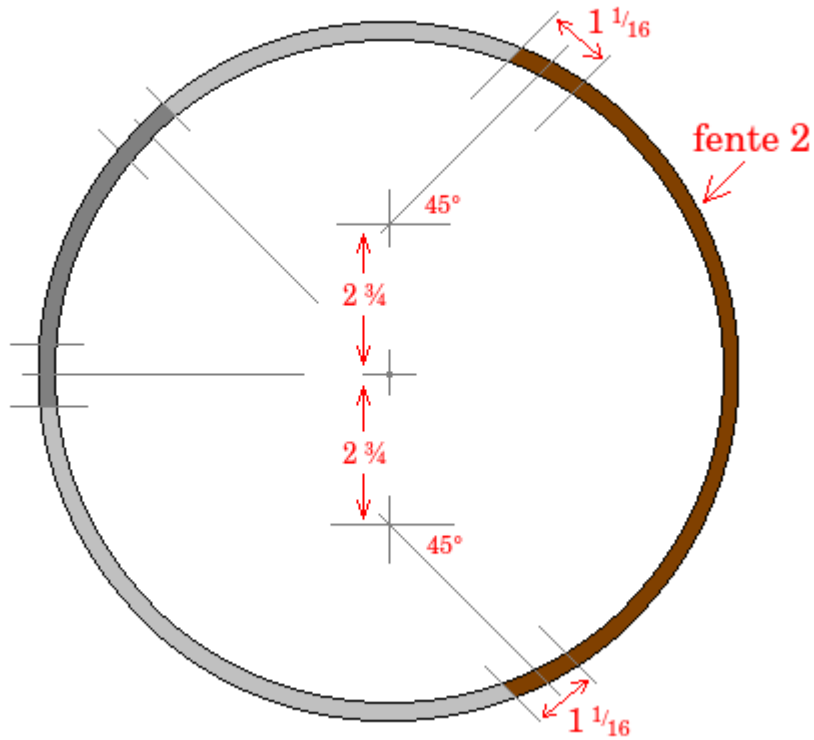

figure 3.f - part p3a, slit 2 (*fente 2*) : top view

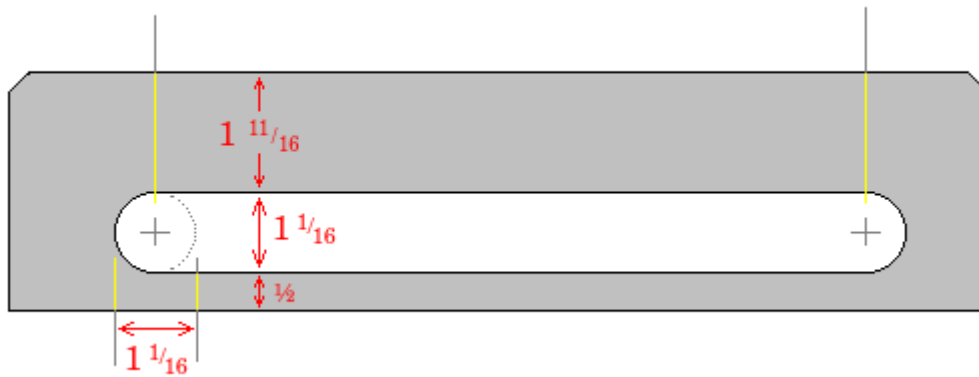

figure 3.g - part p3a, slit 2 : side view

Part p3b

Qty: 1 X

Part p3b is identical to the previous one (p3a) except for the fact that they are mirror copies of one another. The slits are reversed. All the rest remains identical :

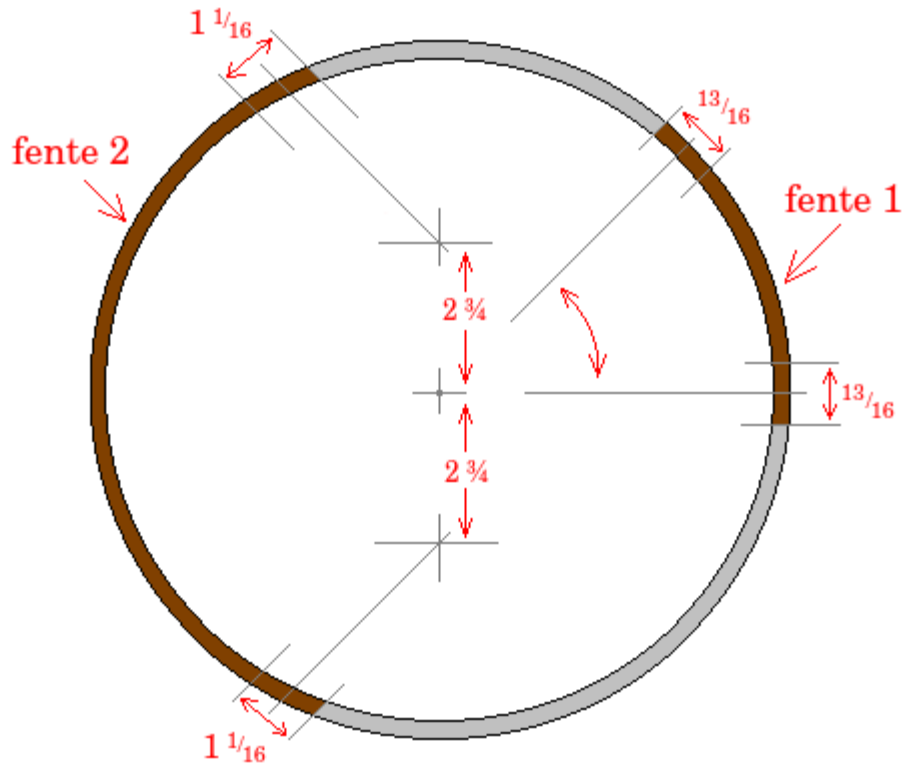

figure 3.h - part p3b, seen from above

Part p4

Qty: 2 X

Part p4 as seen from the front :

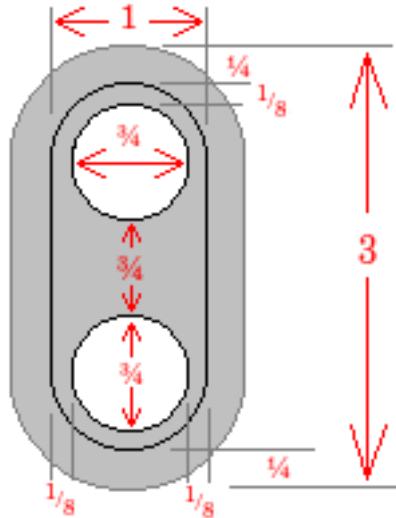

figure 4.a - part p4, front view

The difficulty with this piece is that it needs to follow the contours of a cylindrical surface (part p3, as a matter of fact) upon which it will eventually be positioned. Which means that the lateral portions of p4 which are beveled towards the back of the piece should meet and follow the curved contour of the underlying cylinder:

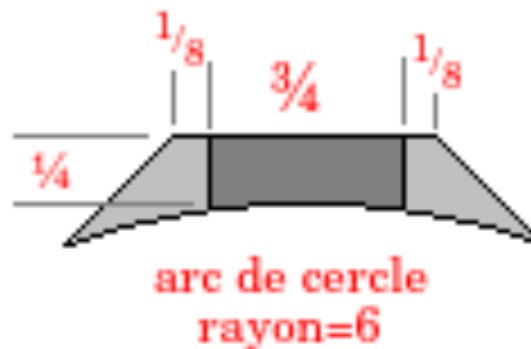

figure 4.b - part p4, top view

...Which should look something like this, as seen in profile :
(The two dark sections obviously represent the locations of the two holes)

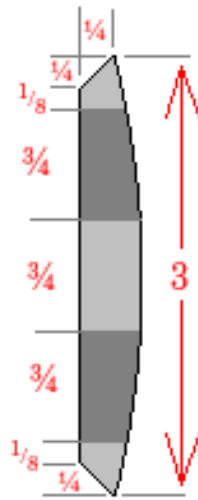

figure 4.c - part p4, profile view